

Jandy®



AE1500
HEAT
PUMPS



Performance

Reliability

Technology



Utilize Air Energy to Heat Your Pool

Efficient, Environmentally Friendly and Cost Effective!

AE1500 Heat Pumps

Jandy heat pumps are the most efficient, trouble-free swimming pool heat pumps in the industry. Heat pumps simply take the heat from the air and transfer it to the water—making the heating process clean, efficient, ecologically safe and most of all, cost effective.

UPGRADED, ENHANCED FEATURES

Advanced Digital Controls

Our redesigned control panel has a backlit display, operating icons, led indicators and user-friendly interface.

Our patented Auto Heat feature maintains pool temperature automatically, 24 hours a day, overriding the pool time clock.

Additional control panels can be installed in your home or cabana to access your heat pump remotely.

Titanium Heat Exchanger

Has a lifetime warranty against corrosion and delivers superior hydraulic flow.

Automation Ready

Built-in pool/spa switching or easy connection to Jandy Controls and other pool/spa automation systems, automatic valve systems, and remotes.

Air Defrost

Allows the heat pump to operate at lower air temperatures.

Extra-Large Evaporator Coil

Our special lanced-fin design collects more heat as the outside temperature starts to drop.

Commercial Grade Compressor

Our improved scroll compressor provides higher heating capacities and is the quietest and most efficient on the market.

See your Jandy Sales Representative for more information



IMPROVED PERFORMANCE!

AE1500 SPECIFICATIONS	
BTU/hr* Output	73k 
C.O.P.	5.6
Voltage	208V-230V/1/60
Supply Circuit	30 AMPS
Compressor	Scroll
Heat Exchanger	Titanium**
Flow Rate G.P.M.	30-125 Optimum
Dimensions (in.)	26½" W/ 31" H/ 36" D
Weight (lbs.)	240

* Tested and Certified according to the 80-80 standard

** Corrosion-Free Technology not affected by chemical imbalances and/or chlorine generators

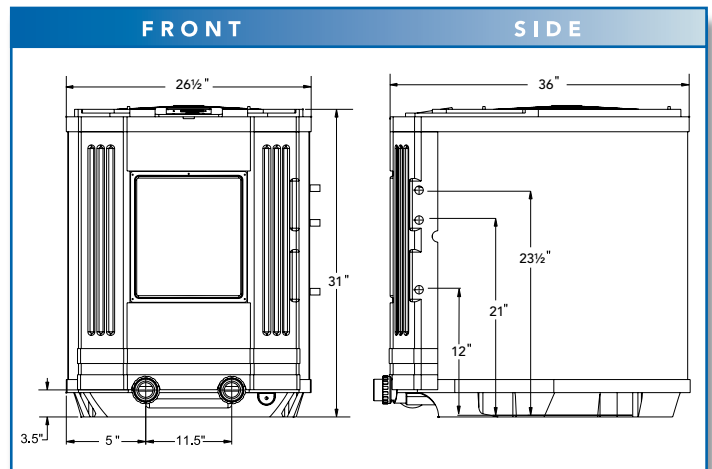

IMPRESSIVE WARRANTY

All Jandy heat pumps are backed by a highly trained technical support department, and by some of the strongest and most inclusive warranties in the industry. See our written warranty for complete details.

CERTIFICATIONS

 Our Heat Pumps are ETL tested to UL specifications

